

Designing Standard-Compliant LTE Schedulers

Mohamed Salah
ECE Department
Queen's University
Kingston, ON
mohamed.salah@queensu.ca

Najah Abu Ali
College of IT
UAE University
Al-Ain, UAE
najah@uaue.ac.ae

Abd-Elhamid Taha
School of Computing
Queen's University
Kingston, ON
taha@cs.queensu.ca

Hossam Hassanein
School of Computing
Queen's University
Kingston, ON
hossam@cs.queensu.ca

Abstract—Long Term Evolution (LTE) was proposed as an evolution of currently deployed 3G technologies to accommodate the forecasted increase in network demand from mobile data services. LTE was introduced with innovative enabling technologies to facilitate achieving LTE's performance target with the help of advanced Radio Resource Management (RRM) schemes. LTE uplink packet scheduling is a RRM entity that ensures good use of network resources by properly scheduling mobile User Equipments (UEs) to radio resources. LTE uplink scheduling takes advantage of advanced antenna techniques and OFDM modulation to promote efficient usage of network resources. LTE uplink scheduling faces challenges due to the properties of utilized enabling technologies, which is handled by hierarchical, per domain scheduling to allow for less complex, efficient scheduling solutions along the uplink radio interface. The design approach of LTE uplink scheduling needs to undergo major enhancements as moving from LTE to LTE-Advanced (LTE-A) to adapt to the enhancements of enabling technologies in LTE-A.

I. INTRODUCTION

As a result of the wide success of 3G networks, mobile subscriptions worldwide has been increasing at an exponential rate to the point that mobile broadband subscriptions are projected to exceed 3.4 Billion subscriptions by 2014, 80% of which are mobile wireless subscriptions [1]. The projected increase in usage of broadband services over HSDPA networks has hastened the rollout of 3G technology, though, as currently deployed HSDPA networks are soon to reach their limits in terms of supporting the forecasted increasing traffic loads of future services. Hence, the 3rd Generation Partnership Project (3GPP) has dictated the need for more advanced mobile technology that is able to meet projected, futuristic demands for at least over the next decade.

LTE was introduced in 2004 as 3GPP Release 8 to stay competitive on the future wireless broadband market, which is realized by meeting the user demands for higher data rate and better QoS support, while at the same time aiming for reducing capital and operational costs. To achieve such goals, 3GPP has focused on introducing technological improvements such as optimizing the packet switch system and reducing the system's complexity [2].

A key feature of LTE is its simplified architecture relative to its predecessor HSDPA [1]. The number of Radio Access Network Interfaces has been reduced in LTE by removing the Radio Network Controller (RNC) present in HSPA. Hence, LTE base stations, termed eNodeBs, are the only unit type present at the radio access. LTE has as well

been introduced with enhanced radio technologies such as advanced antenna techniques, link adaptation, and new radio interface based Orthogonal Frequency Division Multiplexing (OFDM) modulation.

The aforementioned enhancements at the radio access level allows LTE to support a flat, fully IP-based network platform to better support multiple Internet-based services such as IPTV, video steaming, and VoIP as well. Also, the enhancements of LTE's physical layer improves the spectral efficiency and flexible bandwidth scalability. As a result, LTE can achieve high data rates up to 100 Mbps on the downlink and 50 Mbps on the uplink [2].

In order to realize such performance levels, LTE standard must adopt enhanced Radio Resource Management (RRM) utilities that can increase the efficiency of resource utilization while maintaining the multiple QoS requirements of the varied services that run on LTE. The paper presented here focuses on the RRM entity located at the Medium Access Control (MAC) layer at the eNodeB, which is referred to as LTE uplink Packet Scheduler (PS).

An eNodeB packet scheduler is responsible for allocation radio resources to LTE mobile users, also known as User Equipments (UEs), by deciding which UE is to transmit on which time/frequency resource units. The packet scheduler in LTE has to be fully aware of the QoS requirements of different data traffic, especially with increased variety of services running on LTE. In addition, voice calls must be supported as QoS-strict VoIP-based services. Also, the multicarrier nature of OFDM-based radio interface in LTE gives packet scheduler the advantage of exploiting the channel conditions in both time and frequency domains. Thus, LTE packet scheduler can schedule multiple UEs on different frequency bands within the same scheduling period that each UE transmits over part of the bandwidth where it experiences advantageous channel quality. In doing so, LTE packet scheduler promotes multiuser-diversity where the overall channel quality experienced by network is improved to increase the spectral efficiency of the system compared to its predecessor HSDPA standard.

The focus of this article is on the LTE uplink packet scheduling. The article starts with describing the OFDM nature of the radio interface in LTE, along with how radio resources are organized along both the time/frequency domains. Next, we introduce the concept of packet scheduling in LTE and how it operates. The focus then shifts towards the scheduler design

in LTE uplink, where the target goals that the uplink packet scheduler aims for are clearly defined. Packet scheduler design challenges and the approach taken in LTE packet scheduler design are discussed afterwards. Then, we conduct a survey on LTE uplink packet scheduler proposals from literature, after which we provide concluding remarks recommendations pertaining to LTE uplink scheduler design. Then, we end our discussion on considerations to be taken into account when looking at uplink scheduler design in LTE-Advanced.

II. LTE RADIO INTERFACE

LTE employs a multicarrier radio interface which is based on Orthogonal Frequency Division Multiplexing (OFDM) modulation technique [3]. In OFDM, instead of transmitting data packets over a wideband, single carrier, data transmission takes place over multiple orthogonal narrowband subcarriers. OFDM modulation utilizes Inverse Fast Fourier Transform (IFFT) to increase the symbol period of each subcarrier resulting in lower data rates over each subcarrier. The large symbol periods, in addition to the guardband introduced between transmitted symbols, results in overcoming signal distortions as result of Inter-symbol Interference (ISI) effects. The properties of OFDM modulation allows for higher spectral efficiency of the transmission bandwidth, leading to supporting high data rates that can reach a peak rate as high as 100 Mbps in the downlink over a 20 MHz bandwidth.

The LTE standard utilizes the multiple access form of OFDM, namely Orthogonal Frequency Division Multiple Access (OFDMA). The multiple access nature of OFDMA allows for multiple UEs to be multiplexed over the same OFDM symbols. The uplink transmission, on the other hand, utilizes a variant of OFDMA, namely called Discrete Fourier Transform Spread (DFT-S-)OFDMA, or Single Carrier (SC-)FDMA. SC-FDMA is an OFDMA radio interface with the addition of a DFT spreading process that is applied to data symbols before they are mapped to OFDM subcarriers. The DFT spreading helps to overcome the high Peak-to-Average-Power-Ratio (PAPR) that exists in OFDMA transmission. Lower PAPR allows for better power utilization on the uplink and hence reduce power consumption at the UE terminal.

A. OFDM Radio Resource

Before any discussion on LTE packet scheduling, it is greatly beneficial to understand the nature of radio resource units that scheduler Figure 1 illustrates the a frame-based structure of the LTE radio interface in Time Domain (TD). The for both OFDMA and SC-FDMA radio interfaces,

- Radio resources are organized in TD into units spanning 10 ms each, called frames.
- Each time frame is further divided into 10 smaller, 1 ms time blocks called subframe.
- 1 subframe is divided into two slots, each spanning a duration of 0.5 ms.

As also shown in the figure, each 0.5 ms time slot is divided in frequency into blocks of 180 kHz, which contains a block

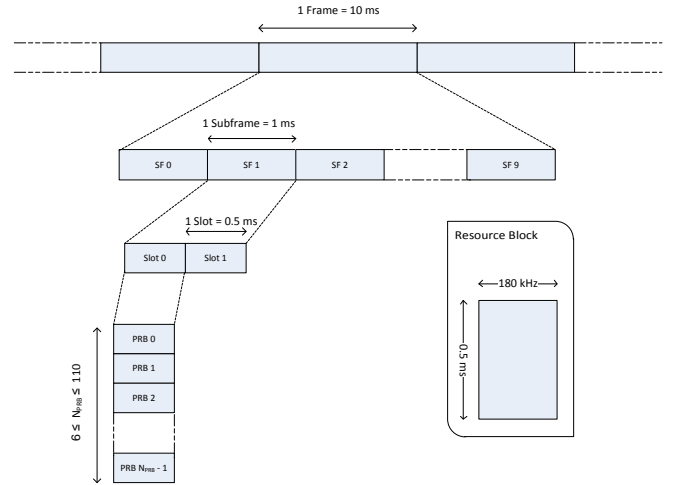

Fig. 1: An illustration of the SC-FDMA Time/Frequency Grid [3]

of 12 subcarriers with a bandwidth of 15 kHz each. A time-frequency block with 0.5 ms duration and 180 kHz in width is referred to as the Physical Resource Block (PRB). Each of the twelve subcarriers in a PRB carries 7 symbols, resulting in a total 84 symbols per PRB, where the number of data bits carried by each symbols is determined by the Modulation and Coding Scheme (MCS) used for transmission.

III. PACKET SCHEDULING IN LTE

LTE packet scheduler is a RRM unit that resides at the MAC layer at the eNodeB, whose major task can be summarized as follows [4]:

- Ensures that radio resources are utilized as efficiently as possible, which aids in reducing the transmission cost per bit
- Ensures that the QoS requirements of multiple services running within LTE network are satisfied.

The scheduler decides which group of PRBs get assigned to which UE within the eNodeB coverage such that the two major goals of scheduling mentioned above are optimized to the best way possible. The scheduling decisions are executed on a periodic basis once every subframe, which is also referred to as Transmission Time Interval (TTI). The UE-to-PRB assignment decisions can be based channel state information (CSI) between the eNodeB and every UE within its coverage, QoS experienced by the UE, buffer status reports on uplink transmission data queues, or any other collected information from the network. The presence of packet scheduler at the eNodeB facilitates fast adaptation to network changes at the access level, which relates to the TTI period's duration being as short as 1 ms.

Also, the multicarrier nature of OFDM modulation has added yet another advantage resource optimization via packet scheduling. That is, scheduling over SC-FDMA allows the uplink packet scheduler to acquire, for each UE, a separate CSI

report for each PRB. The exploitation of channel conditions in TD as well as FD promotes multi-user diversity, in which case the packet scheduler can assign a UE a subset of PRBs over which the UE experiences advantageous channel conditions. This is called Channel-Dependent Scheduling (CDS).

Henceforth, the uplink packet scheduler can perform Link Adaptation (LA) as well, where the packet scheduler adapts the data rate of a UE by assigning it the appropriate Modulation and Coding Scheme (MCS) based on the UE's CSI report over the assigned PRBs.

The LTE standard specifies the signaling procedure for communicating resource requests and resource grants between eNodeB and UEs. Yet, the standard does not specify the scheduling procedure for allocating PRBs to active UEs within the eNodeB's coverage. Hence, many literature work has been presented to provide scheduling solutions that are as close to the optimal solution as possible.

IV. UPLINK PACKET SCHEDULER MODELING

In this section, we present the packet scheduler design modeling, where we start with stating the challenges associated with packet scheduler design in LTE uplink. Afterwards, we introduce the approach of solving the scheduling problem followed by surveys on notable LTE uplink scheduler proposals introduced in literature work.

A. Uplink Scheduler Design Challenges

Despite the advantages provided to packet scheduling in LTE uplink, uplink packet scheduling still face with challenges that can limit its performance when deployed on eNodeBs in real systems.

The first challenge of the scheduler is to find the optimal balance between average per-UE average throughput, fairness among active UEs, and QoS satisfaction. The three performance metrics just mentioned are the most common target of the schedulers' optimization process. However, despite their importance, it is almost impossible to optimize any of these objectives without any degradation on the others. Hence, an intelligent scheduler is the one that optimizes a certain performance metric while minimizing the degradation on other performance metrics.

In addition, the physical layer of the LTE standard introduces a rich collection of enabling radio technologies, such as advanced antenna configurations (beamforming and MIMO) and OFDM modulation. However, the promising performance increase from such technologies comes with the expense of increasing the complexity of the scheduling algorithms to be implemented. As a result, a good scheduler design dictates that utilizing the new enabling technologies in LTE radio interface is achieved without significant increase in algorithm complexity.

Another limitations on the uplink scheduler design is the hard time limitations on scheduling decisions, since the duration of a TTI is only 1 ms. Hence, the hard time limitation presents yet another case for lowering the complexity of the scheduler.

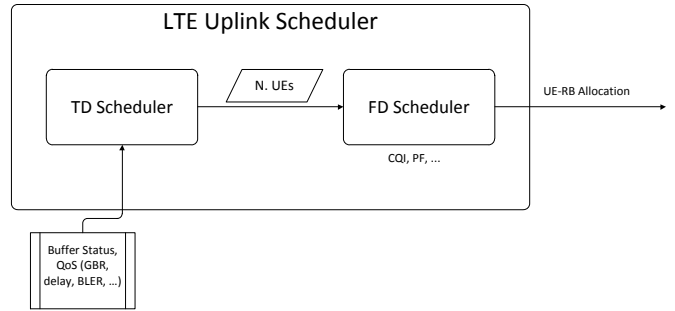

Fig. 2: LTE Uplink Scheduler Model

Power limitation on the uplink transmission presents yet another major challenge for uplink scheduling [5]. Uplink power limitation places limits on scheduling decisions such as the number PRBs allocated to a UE and the data rate at which the UE transmits at.

Another major constraint present in uplink packet scheduling is the contiguity constraint. The contiguity constraint in LTE uplink refers to having all PRBs allocated to a single UE to be adjacent along the frequency domain. This limitation is imposed by the properties of SC-FDMA to minimize the Inter-Symbol-Interference (ISI) introduced by the DFT process. The contiguity constraint reduces the spectral efficiency of the uplink transmission, as this leads to a UE being assigned a PRB despite the presence of other UEs with better channel quality over the same PRB.

B. Scheduler Design Approach

Since LTE scheduling can be viewed as operating in both time and frequency, uplink packet scheduling can be modeled as a two stage operation. The higher level stage of packet scheduling, which can be referred to as TD packet scheduling (TDPS), assigns priorities to UEs. UE prioritization can be derived system changes that changes with time, such as past average throughput, experienced packet delay, or experienced packet error rate.

Once the TDPS process is completed, either all or a subset of UEs get selected for the next phase of packet scheduling. In this lower phase of packet scheduling, alternatively called as FD packet scheduling (FDPS), the packet scheduler performs a rather complex allocation scheme where it traverses through as many UE-PRB mapping possibilities as possible to come up with the assignment pattern that best satisfies the performance target of the system.

The concept was first introduced for LTE downlink scheduling in [6], where the scheduling process is decoupled into a per-domain (time/frequency) scheduling to simplify the process. The phases of the LTE uplink packet scheduling is further illustrated in Figure 2.

V. SCHEDULING ALGORITHMS FOR LTE UPLINK

With the move towards a fully packet switched, IP-based architecture, telephone calls in LTE are being supported as

VoIP traffic over LTE platform, along with other real time services, like IPTV and gaming, as well as non-real time services like web browsing and FTP. QoS support in LTE has thus become more critical than ever such that the end user experiences the voice quality as in circuit switched networks while enjoying the higher data rate for other services as well.

For that purpose, LTE standard supports two major categories of packet scheduling: semi-persistent scheduling, and dynamic scheduling.

A. Semi-Persistent Packet Scheduling

Semi-persistent scheduling has been proposed for both LTE uplink and downlink for the main purpose of providing a circuit-switched-like support for voice services over LTE's packet-switch platform. The main advantage of semi-persistent scheduling is the reduction of control signal overhead involved in the process, since the scheduler would only need to update the resource grants for a UE periodically once every TTIs rather than every TTI. Semi-persistent scheduling makes use of the predictable patterns of the VoIP packet transmissions in updating the resource grants assigned to a given UE with VoIP. During an active VoIP session, the semi-persistent scheduler update the resource allocation to VoIP UE periodically once every TTIs, where in each scheduling period the persistent resource assignment to the VoIP session stays valid. The periodicity pattern of the persistent resource allocation is interrupted events such as retransmissions for previously unsuccessful transmitted packets, changing the allocation assignment based on link adaptation process, or when the VoIP call switches between active and silent periods. At these instances, the scheduler performs dynamic scheduling to accommodate the changes during the session after which the scheduling returns back to persistent scheduling again.

Semi-persistent scheduling was first explored in 3GPP's Work Group (WG) meetings along with other two types of scheduling schemes [7]. Several literature work have followed to further study LTE semi-persistent scheduling as well as introducing semi-persistent scheduling schemes. The authors in [8] performed a study on the LTE uplink VoIP capacity of semi-persistent and dynamic allocation schemes in different environment settings as well as different AMR VoIP rates. The results obtained from their work demonstrated that semi-persistent scheduling can achieve an uplink capacity close to the dynamic scheduling with the use of less control overhead.

The authors from [8] has performed another study where they propose a bidirectional semi-persistent packet scheduler of VoIP traffic [9]. In [9], the bidirectional semi-persistent packet scheduler allocates PRBs that are at one of edges of the spectrum. The algorithm assumes a non-adaptive Hybrid Automatic Repeat Request (HARQ) scheme where the scheduler assigns a UE the same PRB set over which it performed its initial, unsuccessful transmission. Hence, the packet scheduler changes the allocation of new VoIP transmissions to the other edge of the spectrum in case it needs to assign PRBs on the first edge to HARQ retransmissions.

Another proposal for semi-persistent scheduling was introduced in [10]. The algorithm performs VoIP packet scheduling based on a priority mode scheme that protects traffic flows of lower priority from starvation. The packet scheduler works such that it assigns a priority to VoIP traffic flows such that their priority level changes dynamically according the VoIP UE's experienced channel condition. Also, the semi-persistent packet scheduler performs coupling of VoIP UEs such that two UEs are allowed to transmit on the PRBs to increase the utilization of the available spectrum.

B. Dynamic Packet Scheduling

Dynamic packet schedulers perform PRB allocations such that the UE-to-PRB assignment decisions is dynamically updated once every TTI. Dynamic scheduling inherently support traffic flows with large burst sizes, such as web browsing, FTP traffic, and video streaming. Dynamic packet schedulers can also support VoIP traffic flows, where a PS can show great flexibility in performing link adaptation such that a VoIP packets are scheduled on PRBs were with good channel quality. One main difference from semi-persisting scheduling is increased control signaling overhead where a UE has to send to scheduling request for every VoIP packet to be transmitted.

Most of literature work on LTE uplink packet scheduling was done on dynamic packet scheduler design, where the main focus of scheduler proposals is to address maximizing the spectral efficiency of the system's radio bandwidth while respecting the contiguity constraint on PRB allocation, as explained earlier.

Based on the packet scheduler design of surveyed LTE uplink schedulers in literature, they can be classified into four groups: Best-Effort PS, QoS-Aware, Buffer-Aware Schedulers, and Power-Aware Schedulers.

1) *Best-Effort Schedulers*: Schedulers in this category mostly rely on either max Carrier-to-Interference (max C/I) or Proportional Fairness (PF) as the main utility function such that they provide a utility-based metric for each UE at every schedulable PRB. The main target of Best-Effort Schedulers is to maximize the utilization of the available radio spectrum with the help of CDS-based allocation method. Schedulers with PF-based utility function try to promote, in addition to spectral efficiency, inter-UE fairness protect UEs with lower channel quality from starvation. Therefore, schedulers in this category are best suited for non-real time and best effort traffic, as they provide no means for QoS-provisioning of the traffic flows they try to schedule.

An example of Best-Effort scheduling is the work presented in [11]. The authors from [11] have proposed another scheduler in [12] that employs 'Adaptive Transmission Bandwidth (ATB)' in which the size of PRB set allocated to UEs can either shrink or expand depending on the UE's PF metric at each PRB. The algorithm also takes power allocation into account such that the schedulers stops allocating PRBs to a UE if it is to exceed its power budget. ATB-based scheduling gives more flexibility in resource allocation such that the the

scheduler can maximize the PF-utility further than both FTB-based schedulers can. However, ATB scheduling can allow a single UE to dominate most of the PRBs within a single TTI, which impacts the multi-user diversity supported by SC-FDMA and in turn the fairness of resource allocation among UEs.

2) *QoS-Aware Schedulers*: QoS-Aware schedulers aim to optimize modified PF-utility functions that incorporate QoS terms such as GBR and average delay. Such improvements allows them to better support GBR traffic with stricter GBR and delay requirements, as well as scenarios with traffic mixtures.

One of the early proposals was presented in [13], where the authors have proposed an uplink scheduler termed as ‘Proportional Fairness with Guaranteed Bit Rate’ algorithm, or PFGBR. PFGBR was proposed with using two different metrics, a PF utility for UEs with non-real time traffic, and another PF utility GBR-based term for UEs with wit GBR traffic. Such Utility scheme allows for the accommodating scenarios with UEs from different GBR and non-GBR traffic classes.

3) *Power-Aware Schedulers*: LTE uplink schedulers in this category aim at minimizing UE’s transmission power to conserve their battery life. Based on the proposals present in literature, power-aware schedulers perform power-optimizing resource allocations based on their awareness of QoS requirements of the uplink traffic held by active UEs.

An LTE uplink scheduler proposal was presented in [14], where the scheduler based on delay-bounded power optimization scheme. The concept behind the scheduler revolves around increasing the experienced delay of packet traffic to reduce the uplink data rate of the UE, and hence reduce the power consumption. The relaxation of the experienced delay is bounded in this case by the packet delay budget of the QoS class to which the UE’s uplink traffic belongs to.

C. MU-MIMO Uplink Scheduling in LTE

Most of the scheduling algorithms proposed in literature for LTE uplink, including the ones just discussed above, assume that any given PRB can be assigned to no more than one UE at any given TTI, as illustrated in Figure . This is due to UE equipment having a single antenna as the default antenna configuration, limiting the number of uplink streams to one per UE [5]. However, the eNodeB is equipped with at least 2 receive antennas, which provides options for utilization advanced antenna techniques to increase the LTE system performance [15].

Multi-user (MU-)MIMO scheduling has been introduced to LTE as a Spatial Division Multiple Access (SDMA) scheme that allows to multiplex more than one UE onto the same bandwidth over which paired UEs can transmit simultaneously, as shown in Figure . The number of paired UEs is decided by the number of receive antennas at the UE.

MU-MIMO can be viewed as a spatial scheduling done at a higher layer above TDPS/FDPS scheduling model demonstrated in Figure 2. With the inclusion of spatial

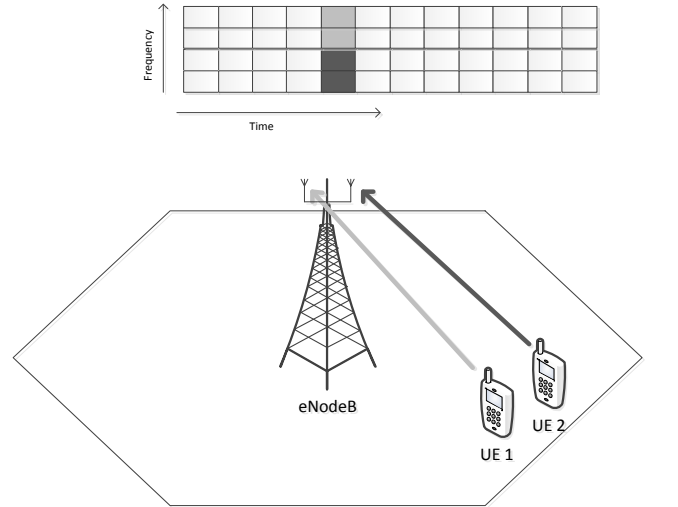

Fig. 3: Uplink Transmission with single transmit antenna

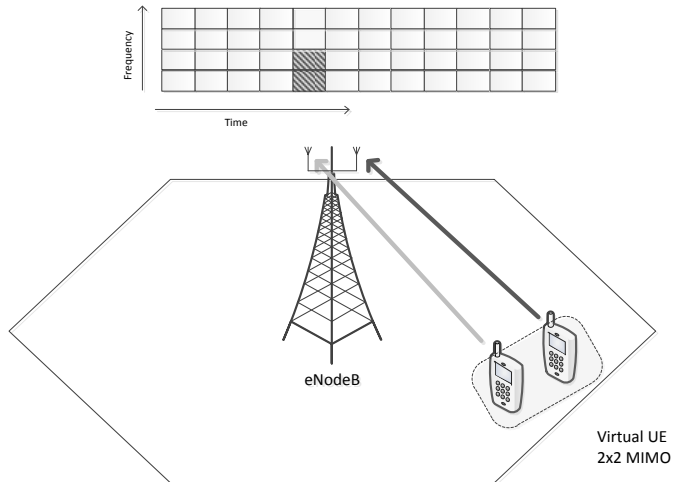

Fig. 4: MU-MIMO Uplink Transmission

scheduling based on MU-MIMO, the uplink scheduling model can be illustrated as in Figure 5

MU-MIMO in LTE was first discussed in [16] and [17], where initial performance evaluations showed encouraging performance improvements similar to 2×2 MIMO configuration. Further work was done in literature, where the authors in [18] have proposed an SNR-based MU-MIMO scheduling scheme. The proposed MU-MIMO scheduler utilizes an SNR-based factor that is adjustable to compromise between the system throughput and fairness among UEs.

Despite that the concept of MU-MIMO in LTE has been around since the early days of LTE Release 8, very few

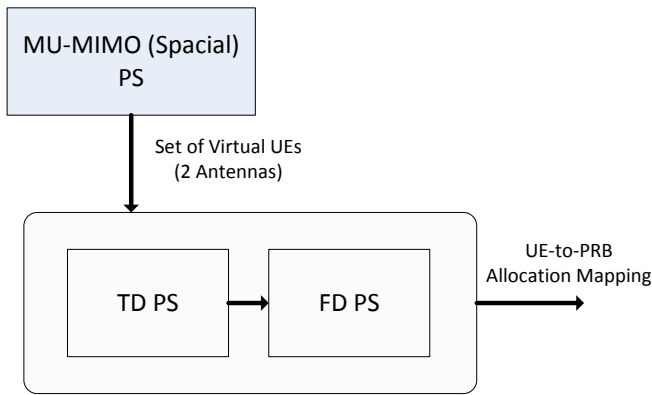

Fig. 5: LTE Uplink Scheduling Model with MU-MIMO.

literature work has addressed the topic, as most of the effort on LTE uplink scheduling was more focused on overcoming the contiguity constraint in PRB allocation as an obstacle towards increasing the system's spectral efficiency on the LTE uplink.

VI. UPLINK SCHEDULING IN LTE-A: CONSIDERATIONS

With both LTE releases, Release 8 and Release 9, finalized, 3GPP is currently on its way to finalizing the next 3GPP release which is regarded as the next revolutionary step after LTE, LTE-Advanced (LTE-A). In the move from LTE to LTE-A, 3GPP had to introduce several enhancements on the radio interface and system access architecture that can have a significant impact on uplink scheduling design for LTE-A.

Once major enhancement to the radio interface of LTE-A is the introduction of Carrier Aggregation (CA). CA is a crucial technology that enables LTE-A to support bandwidth sizes larger than 20 MHz. CA refers to aggregating two or more LTE carriers to form a bandwidth as large as 100 MHz. Multiple CA modes exist for LTE-A that support both contiguous and non-contiguous aggregation of LTE carriers. The different CA modes implies that the uplink radio interface of LTE-A becomes an aggregation of multiple SC-FDMA bandwidths, which is denoted as Aggregated DFT-Spread-OFDMA (NxDFT-S-OFDMA). The new aggregated radio interface in LTE-A thus can support both contiguous and non-contiguous resource allocation.

Also, LTE-A-compliant UE units are to be equipped with at least two transmit antennas, while eNodeBs are to have four receive antennas. Therefore, MIMO support in LTE uplink scheduler becomes a must to utilize newly available MIMO techniques in increasing the uplink capacity and coverage for LTE-A.

Also, 3GPP introduces Coordinated Multi-Point transmission/reception (CoMP) as a key feature in LTE-A architecture to improve coverage, cell-edge throughput, as well as spectral efficiency. CoMP technology is a cooperative technique that

allow a cell-edge UE to receive its downlink or send its uplink data to multiple cell sites. Cell sites here can either refer to eNodeBs from different cell coverages, or eNodeB and relay stations within the same cell coverage. The introduction of CoMP technology dictates having packet distributed scheduling schemes that enable multiple sites to coordinate their communications to a single UE to avoid interference scenarios.

VII. CONCLUSION

LTE is a major step towards to evolution from current 3G technologies which as it provides the necessary means to supporting the drastic increase in data traffic loads from the multiple IP-based services that are expected to run over LTE interface. The simplified architecture, OFDM modulation, advanced antenna techniques, and strong support for QoS are all key features of LTE to achieve its promised performance objectives. RRM is a crucial component of LTE to manage the network resources in such a way to increase the data rate and hence the efficiency of utilizing these resources. LTE uplink packet scheduling plays a major role as part of RRM to ensure good resource usage by properly allocating PRB resources to UEs. LTE uplink packet scheduling design needs to address certain challenges to ensure smooth operation along the LTE uplink interface. Performance challenges include the proper balance between different performance metrics, the hard time constraints, ensuring low complexity solutions with the proper utilization of advanced antenna techniques and OFDM-based scheduling, power limitation of uplink transmissions, and the contiguity constraint on allocating time-frequency resources. LTE uplink scheduling is approached by per domain scheduling. First, Time Domain scheduling is performed on UEs to select which UEs to be scheduling for the upcoming TTI. Afterwards, Frequency Domain scheduling is performed next to multiplex selected UEs over the available frequency resources. LTE also provides support for MU-MIMO scheduling, in which UEs with single antennas are paired according to a certain pairing scheme to create a 'virtual' UEs with two transmit antennas. Uplink packet scheduling can then be performed on 'virtual' UEs using the per-domain scheduling approach assuming a 2x2 MIMO configuration. Uplink scheduling design approach in needs to evolve as moving from LTE towards LTE-A to accommodate the changes in enabling technologies.

ACKNOWLEDGMENT

This work is supported by a grant from the Natural Science and Engineering Research Council of Canada (NSERC) and by a grant from Qatar Foundation (QF) under the National Priorities Research Program (NPRP).

REFERENCES

- [1] Ericsson, "Long Term Evolution (LTE) - An Introduction," ts, Ericsson, June 2009.
- [2] "Overview of 3gpp release 8," 2011. Available from <http://www.3gpp.org/Release-8>; accessed 23 March 2011.

- [3] 3GPP, "Evolved Universal Terrestrial Radio Access (E-UTRA); Physical Channels and Modulation," TR 36.211, 3rd Generation Partnership Project (3GPP), Mar. 2010.
- [4] S. Sesia, I. Toufik, and M. Baker, *LTE, The UMTS Long Term Evolution: From Theory to Practice*. Wiley Publishing, 2009.
- [5] 3GPP, "Evolved Universal Terrestrial Radio Access (E-UTRA); User Equipment (UE) Radio Transmission and Reception," TS 36.101, 3rd Generation Partnership Project (3GPP), June 2010.
- [6] G. Mongha, K. Pedersen, I. Kovacs, and P. Mogensen, "Qos oriented time and frequency domain packet schedulers for the utran long term evolution," in *Vehicular Technology Conference, 2008. VTC Spring 2008. IEEE*, pp. 2532 –2536, May 2008.
- [7] 3GPP, "Uplink Scheduling for VoIP," TS R2-070476, 3rd Generation Partnership Project (3GPP), Feb. 2007.
- [8] H. Wang, D. Jiang, and E. Tuomaala, "Uplink Capacity of VoIP on LTE System," in *Communications, 2007. APCC 2007. Asia-Pacific Conference on*, pp. 397 –400, Oct. 2007.
- [9] H. Wang and D. Jiang, "A Novel Bidirectional Resource Allocation to Decrease Signaling for Retransmission in LTE System," in *Vehicular Technology Conference, 2008. VTC Spring 2008. IEEE*, pp. 2269 –2271, May 2008.
- [10] S. Saha and R. Quazi, "Priority-coupling-a semi-persistent mac scheduling scheme for voip traffic on 3g lte," in *Telecommunications, 2009. ConTEL 2009. 10th International Conference on*, pp. 325 –329, June 2009.
- [11] F. Calabrese, P. Michaelsen, C. Rosa, M. Anas, C. Castellanos, D. Villa, K. Pedersen, and P. Mogensen, "Search-Tree Based Uplink Channel Aware Packet Scheduling for UTRAN LTE," in *Vehicular Technology Conference, 2008. VTC Spring 2008. IEEE*, pp. 1949 –1953, 11-14 2008.
- [12] F. Calabrese, C. Rosa, M. Anas, P. Michaelsen, K. Pedersen, and P. Mogensen, "Adaptive Transmission Bandwidth Based Packet Scheduling for LTE Uplink," in *Vehicular Technology Conference, 2008. VTC 2008-Fall. IEEE 68th*, pp. 1 –5, 21-24 2008.
- [13] P. Wen, M. You, S. Wu, and J. Liu, "Scheduling for Streaming Application over Wideband Cellular Network in Mixed Service Scenarios," in *Military Communications Conference, 2007. MILCOM 2007. IEEE*, pp. 1 –7, Oct. 2007.
- [14] Z. Li, C. Yin, and G. Yue, "Delay-bounded power-efficient packet scheduling for uplink systems of lte," in *Wireless Communications, Networking and Mobile Computing, 2009. WiCom '09. 5th International Conference on*, pp. 1 –4, Sept. 2009.
- [15] 3GPP, "Evolved Universal Terrestrial Radio Access (E-UTRA); Base Station (BS) radio transmission and reception," TS 36.104, 3rd Generation Partnership Project (3GPP), June 2010.
- [16] Nortel, "UL Virtual MIMO System Level Performance Evaluation for E-UTRA," TS R1-051422, 3rd Generation Partnership Project (3GPP), Nov. 2005.
- [17] Nortel, "UL virtual MIMO transmission for E-UTRA," TS R1-0501162, 3rd Generation Partnership Project (3GPP), Oct. 2005.
- [18] Y. Chao, F. Bin, Q. Yu, and W. Wen-bo, "Adjustable determinant pairing scheduling for virtual mimo system," in *Intelligent Signal Processing and Communication Systems, 2007. ISPACS 2007. International Symposium on*, pp. 626 –629, Dec. 2007.